

1028815

Description: 2-1/2" off-road X-pipe for 1994-1995 Mustang 5.0L both LX and GT.

OFF-ROAD RACE USE ONLY!! This product is not intended for use on public roads.

Instructions:

DO NOT TIGHTEN ANY BOLTS OR CLAMPS UNTIL THE LAST STEP!!

1) Remove the oxygen sensors and the air tube (at the clamp before the air tube splits to the two sides) from the original H-pipe. You will need to remove the air tube mount on the vehicle to the original H-pipe, and disconnect the factory hanger for both sides. Remove the original H-pipe from the car, unbolting the system at the manifolds (or factory shorty-headers) and at the flanges at the middle of the vehicle. Leave the existing rear extension pipes, mufflers and tail pipes in place unless you will be installing another replacement system.

NOTE: you will need to re-use the manifold studs and nuts, and also the original air tube clamp, to install this system. Hardware is included for bolting the rear of the system to your existing exhaust system.

2) Install the driver's side of the X-pipe (left front section) to the driver's side manifold, using the original hardware.

3) Repeat step 2) for the passenger side pipe.

4) Install the rear section X-pipe to the front sections, using 2-1/2" clamps.

5) Connect the rear flanged sections of the rear section X-pipe to the existing rear exhaust system using the 3/8" x 2-1/2" bolts, nuts, lock washers, and two fender washers per bolt hole on the flanges.

6) Install the oxygen sensors to the appropriate oxygen sensor nut of each front section. Attach the air tube from the vehicle to the air tube on the X-pipe re-using the original air tube clamp.

7) Tighten all clamps and bolts. Check for clearance, leaks and rattles.

KIT CONTENTS:

- | | |
|---------------------------|---------------------------------|
| 2) 2-1/2" clamps | 1) left front section 1028815L |
| 4) 3/8" x 2-1/2" bolts | 1) right front section 1028815R |
| 4) 3/8" nuts | 1) rear section X-pipe MUSTXP |
| 4) 3/8" lock washers | |
| 8) fender washers (33219) | |

1028815

DANGER WARNING: Should the purchaser decide to install this exhaust product at home, be warned that pleasure car or light duty truck/van “bumper” jacks are intended for emergency use only. The use of frame contact jack stands in conjunction with a floor jack as main support is highly recommended to minimize accidental dropping of a vehicle while the installation proceeds.

Limitation of liability--Disclaimers: The regulation of emissions production, noise levels and safety standards is undertaken by the federal government, each of the fifty state legislatures, and by many local municipalities, towns and counties.

The manufacturer makes no warranties of merchantability, of fitness for a particular purpose, or that its products are approved for general use, or that its products comply with laws, regulations or ordinances in the states where they may be sold to the ultimate purchaser, the consumer.

The entire risk as to the conformity of this product in any such state and as to repair, should the product prove to be defective or non-conforming, is on the retail purchaser, the buyer, the ultimate consumer of such product and it is not upon the seller, distributor, or manufacturer.

In this connection, retail purchaser, the buyer, the ultimate consumer assumes the burden of the entire cost of any and all necessary service, alterations, and or repair.

The foregoing statement limits the liability of the manufacturer.

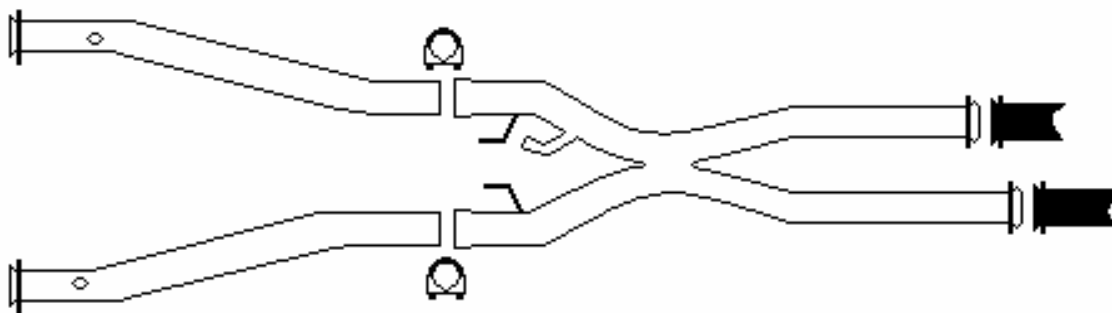

Heartthrob exhaust systems are manufactured by Heartthrob Exhaust--Litchfield, MN

Email us at mike@heartthrobexhaust.com with any questions. www.heartthrobexhaust.com
320-693-0222

BUILD SHEET FOR: MUSTANG X-PIPE

PART#'S: 1028815

- ____ 1) REAR SECTION X-PIPE #MUSTXP
- ____ 1) RIGHT FRONT SECTION #1028815R
- ____ 1) LEFT FRONT SECTION #1028815L
- ____ 1) HARDWARE KIT

INSPECTED BY: _____

DATE: _____

INSPECTED BY: _____

DATE: _____

BUILD SHEET FOR: MUSTANG X-PIPE

PART#'S: 1028815

- ____ 1) REAR SECTION X-PIPE #MUSTXP
- ____ 1) RIGHT FRONT SECTION #1028815R
- ____ 1) LEFT FRONT SECTION #1028815L
- ____ 1) HARDWARE KIT

INSPECTED BY: _____

DATE: _____

INSPECTED BY: _____

DATE: _____

BUILD SHEET FOR: MUSTANG X-PIPE

PART#'S: 1028815

- ____ 1) REAR SECTION X-PIPE #MUSTXP
- ____ 1) RIGHT FRONT SECTION #1028815R
- ____ 1) LEFT FRONT SECTION #1028815L
- ____ 1) HARDWARE KIT

INSPECTED BY: _____

DATE: _____

INSPECTED BY: _____

DATE: _____