

INSTRUCTIONS FOR KIT #2005014 DUAL KIT

FITS 2002-2005 FULL-SIZE DODGE 1/2 TON RAM W/ 3.7L V6, 4.7L & 5.9L V8, 2WD & 4WD, ALL WHEEL BASES, DOES NOT FIT DIESEL, AND V-10.

NOTE: DO NOT TIGHTEN ANY CLAMPS OR BOLTS UNTIL THE LAST STEP!

1) REMOVE THE EXHAUST SYSTEM AT THE CLAMP BEHIND THE CONVERTER LEAVING ONLY THE ORIGINAL Y PIPE, RUBBER MOUNTS, AND CATALYTIC CONVERTER ON THE TRUCK.

2) THE EXTENSION PIPE WILL FIT THE 160.5" WHEEL BASE TRUCKS (QUAD CAB LONG BOX) WITHOUT CUTTING. ON THE QUAD CAB SHORT BOX AND REGULAR CAB LONG BOX (140.5" W.B.) THE EXTENSION PIPE WILL NEED TO BE CUT FROM THE **3" O.D.** END (THE END THAT IS NOT SHRUNK). CUT TO 36" ON THESE VEHICLES, AND FOR REGULAR CAB SHORT BOX (120.5" W.B.) CUT TO 16" FROM THE 3" O.D. END.

3) USE THE 2-1/2" CLAMP TO ATTACH THE EXTENSION PIPE TO THE CONVERTER PIPE, BE SURE TO MATCH UP THE NOTCH.

4) SLIDE THE 3" HANGER CLAMP OVER THE EXTENSION PIPE. ATTACH THE 3" HANGER CLAMP TO THE O.E. RUBBER MOUNT BESIDE THE EXTENSION PIPE.

5) INSTALL THE MUFFLER. USE THE 3" MUFFLER CLAMP TO ATTACH THE INLET OF THE MUFFLER AND THE EXTENSION PIPE TOGETHER.

6) INSTALL THE LEFT TAIL PIPE TO THE MUFFLER. IT HAS 3 BENDS AND THE SHORT END IS THE INLET (IT ALSO HAS A LESSER DEGREE OF BEND ON THE INLET). THE LEFT TAIL PIPE RUNS BETWEEN THE SHOCK AND THE FRAME.

7) INSTALL THE LEFT 2-1/4" HANGER CLAMP (SHORTER) TO THE O.E. RUBBER MOUNT ABOVE THE LEFT TAIL PIPE JUST AFTER THE MUFFLER. ATTACH THE LEFT 2-1/4" HANGER CLAMP TO THE CONNECTING POINT OF THE LEFT TAIL PIPE AND MUFFLER.

8) LOCATE OR DRILL A HOLE IN THE FRAME NEAR THE END OF THE OVER THE AXLE SECTION OF THE LEFT TAIL PIPE. (THERE IS A LARGE 1" HOLE THAT IS IDEAL). USING THE 3/8" X 3-1/2" BOLT, NUT, LOCK, AND LARGE AND FENDER WASHERS (install the smaller washer to the bolt first, then the larger washer), INSTALL A BR91930 (360 SWINGER HANGER) TO THE FRAME AND ATTACH TO THE LEFT TAIL PIPE USING A 2-1/4" CLAMP. YOU MAY NEED TO BEND THIS HANGER AT A 90 DEGREE ANGLE FOR PROPER FIT.

9) INSTALL THE RIGHT TAIL PIPE TO THE MUFFLER. IT HAS 5 BENDS AND THE SHORT END IS THE INLET. ATTACH THE RIGHT 2-1/4" HANGER CLAMP (LONGER) TO THE O.E. RUBBER HANGER MOUNT ABOVE THE RIGHT TAIL PIPE JUST AFTER THE MUFFLER. ATTACH THE RIGHT 2-1/4" HANGER CLAMP TO THE CONNECTING POINT OF THE RIGHT TAIL PIPE AND MUFFLER.

10) LOCATE OR DRILL A HOLE IN THE FRAME NEAR THE END OF THE OVER THE AXLE SECTION OF THE RIGHT TAIL PIPE. (THERE IS A LARGE 1" HOLE THAT IS IDEAL). USING THE 3/8" X 3-1/2" BOLT, NUT, LOCK, AND LARGE AND FENDER WASHERS (install the smaller washer to the bolt first, then the larger washer), INSTALL A BR91930 (360 SWINGER HANGER) TO THE FRAME AND ATTACH TO THE RIGHT TAIL PIPE USING A 2-1/4" CLAMP. YOU MAY NEED TO BEND THIS HANGER AT A 90 DEGREE ANGLE FOR PROPER FIT.

11) USING 2-1/4" CLAMPS, INSTALL AN I.D/O.D TAIL PIPE EXTENSION TO THE LEFT AND RIGHT TAIL PIPES. (YOU WILL WANT TO TRIM THE EXTENSIONS TO YOUR DESIRED LENGTH.)

12) TIGHTEN ALL CLAMPS AND BOLTS AND CHECK FOR CLEARANCE OF THE FRAME, BODY, AND BRAKE AND FUEL LINES.

Heartthrob exhaust systems are manufactured by Heartthrob Exhaust—Litchfield, MN

Email us at mike@heartthroboxhaust.com with any questions.

www.heartthroboxhaust.com 320-693-0222

HARDWARE KIT FOR KIT #2005014:

- | | |
|--|--|
| 1) FRONT EXTENSION PIPE (SHRUNK) #2005510-1L | 1) LEFT TAIL PIPE #2005000-2 |
| 1) RIGHT TAIL PIPE #2005000-3 | 2) TAIL PIPE EXTENSIONS 30" #2005000-7 |
| 1) MUFFLER #54441 | |
| 1) 2-1/2" CLAMP | 1) 3" CLAMP |
| 1) 3" HANGER CLAMP-#2905 | 4) 2-1/4" CLAMPS |
| 1) LEFT 2-1/4" HANGER CLAMP-#2904 | 2) 360 SWINGER HANGER--(BR91930) |
| 2) 3/8" X 3-1/2" BOLTS | 2) 3/8" NUTS |
| 2) #33012 1/2" LARGE WASHERS | 2) #33219 3/8" FENDER WASHERS |
| 2) 3/8" LOCK WASHERS | 1) RIGHT 2-1/4" HANGER CLAMP-#2903 |

DANGER WARNING: SHOULD THE PURCHASER DECIDE TO INSTALL THIS, OR ANY OTHER EXHAUST PRODUCT AT HOME, BE WARNED THAT PLEASURE CAR OR LIGHT DUTY TRUCK/VAN "BUMPER JACKS" ARE INTENDED FOR EMERGENCY USE ONLY. THE USE OF FRAME CONTACT JACK STANDS IN CONJUNCTION WITH A FLOOR JACK AS MAIN SUPPORT IS HIGHLY RECOMMENDED TO MINIMIZE ACCIDENTAL DROPPING OF A VEHICLE WHILE THE INSTALLATION PROCEEDS.

Limitation of liability--Disclaimers: The regulation of emissions production, noise levels and safety standards is undertaken by the federal government, each of the fifty state legislatures, and by many local municipalities, towns and counties.

The manufacturer makes no warranties of merchantability, of fitness for a particular purpose, or that its products are approved for general use, or that its products comply with laws, regulations or ordinances in the states where they may be sold to the ultimate purchaser, the consumer.

The entire risk as to the conformity of this product in any such state and as to repair, should the product prove to be defective or non-conforming, is on the retail purchaser, the buyer, the ultimate consumer of such product and it is not upon the seller, distributor, or manufacturer.

In this connection, retail purchaser, the buyer, the ultimate consumer assumes the burden of the entire cost of any and all necessary service, alterations, and or repair.

The foregoing statement limits the liability of the manufacturer.

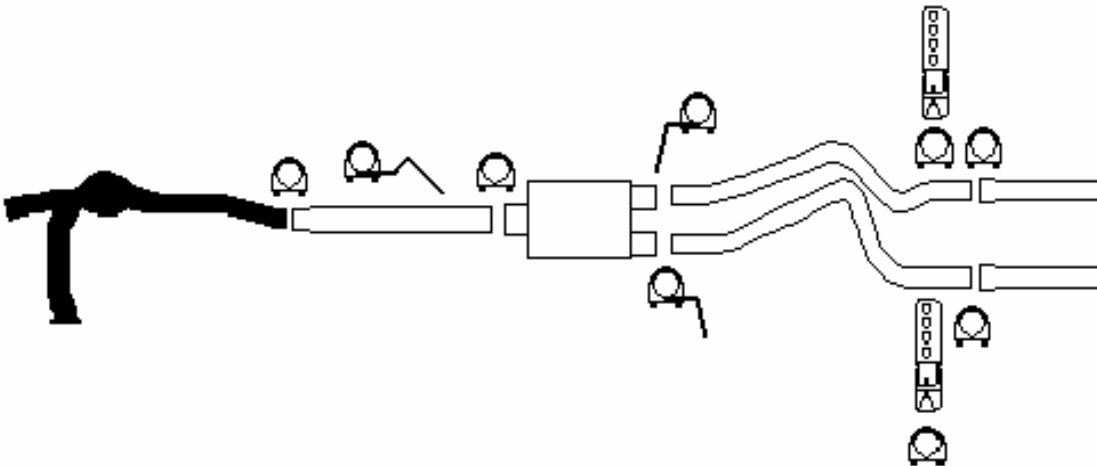

BUILD SHEET FOR: 2-1/4" DUAL KIT W/HVS

PART #: 2005014

- ____ 1) FRONT EXTENSION PIPE (SHRUNK) #2005510-1L
- ____ 1) LEFT TAIL PIPE #2005000-2
- ____ 1) RIGHT TAIL PIPE #2005000-3
- ____ 2) TAIL PIPE EXTENSIONS 30" #2005000-7
- ____ 1) MUFFLER #54441
- ____ 1) HARDWARE KIT

INSPECTED BY: _____

DATE: _____

INSPECTED BY: _____

DATE: _____

BUILD SHEET FOR: 2-1/4" DUAL KIT W/HVS

PART #: 2005014

- ____ 1) FRONT EXTENSION PIPE (SHRUNK) #2005510-1L
- ____ 1) LEFT TAIL PIPE #2005000-2
- ____ 1) RIGHT TAIL PIPE #2005000-3
- ____ 2) TAIL PIPE EXTENSIONS 30" #2005000-7
- ____ 1) MUFFLER #54441
- ____ 1) HARDWARE KIT

INSPECTED BY: _____

DATE: _____

INSPECTED BY: _____

DATE: _____