

INSTRUCTIONS FOR KIT #2005015 DUAL KIT

FITS 2002-2005 FULL-SIZE DODGE 1/2 TON RAM W/ 3.7L V6, 4.7L & 5.9L V8, 2WD & 4WD, ALL WHEEL BASES, DOES NOT FIT DIESEL, HEMI, AND V-10.

NOTE: DO NOT TIGHTEN ANY CLAMPS OR BOLTS UNTIL THE LAST STEP!

1) REMOVE THE EXHAUST SYSTEM AT THE CLAMP BEHIND THE CONVERTER LEAVING ONLY THE ORIGINAL Y PIPE, RUBBER MOUNTS, AND CATALYTIC CONVERTER ON THE TRUCK.

2) BOTH OF THE EXTENSION PIPES WILL FIT THE 160.5" WHEEL BASE TRUCKS (QUAD CAB LONG BOX) WITHOUT CUTTING. ON ALL OTHER WHEEL BASE MODELS (140.5" = QUAD CAB SHORT BOX AND REGULAR CAB LONG BOX, 120.5" = REGULAR CAB SHORT BOX), CUT AS NECESSARY FOR A PROPER FIT.

3) USE THE 2-1/2" CLAMP TO ATTACH THE EXTENSION PIPE TO THE CONVERTER PIPE, BE SURE TO LINE UP THE NOTCH.

4) SLIDE THE FRONT 2-1/2" HANGER CLAMP OVER THE EXTENSION PIPE. ATTACH THE HANGER CLAMP TO THE O.E. RUBBER MOUNTING BRACKET BESIDE THE EXTENSION PIPE.

5) USE A 2-1/2" MUFFLER CLAMP TO ATTACH THE INLET OF THE MUFFLER AND THE EXTENSION PIPE TOGETHER.

6) INSTALL THE LEFT TAIL PIPE (4 BENDS, LONG END IS THE INLET) USING THE LEFT 2-1/2" HANGER CLAMP (SHORTER) TO THE LEFT OUTLET OF THE MUFFLER. CONNECT THE WIRE PORTION OF THE HANGER TO THE O.E. RUBBER MOUNT ABOVE THIS CONNECTING POINT.

7) INSTALL A TAIL PIPE EXTENSION TO THE LEFT TAIL PIPE USING A 2-1/2" CLAMP.

8) LOCATE OR DRILL A HOLE IN THE FRAME NEAR THE MIDDLE OF THE LEFT TAIL PIPE EXTENSION. (THERE IS A LARGE 1" WIDE HOLE THAT IS IDEAL TO USE). USING THE 3/8" X 3-1/2" BOLT, NUT, LOCK, FENDER AND LARGE WASHER (INSTALL THE SMALLER FENDER WASHER TO THE BOLT FIRST, THEN INSTALL THE LARGER WASHER), INSTALL THE BR91930 (360 SWINGER HANGER) TO THE FRAME AND ATTACH TO THE LEFT TAIL PIPE EXTENSION USING A 2-1/2" CLAMP.

9) INSTALL THE RIGHT TAIL PIPE (5 BENDS, SHORT END IS THE INLET) USING THE RIGHT 2-1/2" HANGER CLAMP (LONGER) TO THE RIGHT OUTLET OF THE MUFFLER. CONNECT THE WIRE PORTION OF THE HANGER TO THE O.E. RUBBER MOUNT ABOVE THIS CONNECTING POINT.

10) LOCATE OR DRILL A HOLE IN THE FRAME NEAR THE CONNECTING POINT OF THE RIGHT TAIL PIPE AND THE RIGHT TAIL PIPE EXTENSION. (THERE IS A LARGE 1" WIDE HOLE THAT IS IDEAL TO USE). USING THE 3/8" X 3-1/2" BOLT, NUT, LOCK, FENDER AND LARGE WASHER (INSTALL THE SMALLER FENDER WASHER TO THE BOLT FIRST, THEN INSTALL THE LARGER WASHER), INSTALL THE BR91930 (360 SWINGER HANGER) TO THE FRAME AND ATTACH TO THE RIGHT TAIL PIPE AND EXTENSION USING A 2-1/2" CLAMP. (YOU WILL WANT TO TRIM BOTH OF THE EXTENSIONS TO YOUR DESIRED LENGTH.)

11) TIGHTEN ALL CLAMPS AND BOLTS AND CHECK FOR CLEARANCE OF THE FRAME, BODY, AND BRAKE AND FUEL LINES.



HARDWARE KIT FOR KIT #2005015:

- 7) 2-1/2" CLAMPS
- 1) FRONT 2-1/2" HANGER CLAMP-# 2969
- 1) LEFT 2-1/2" HANGER CLAMP-# 2968
- 1) RIGHT 2-1/2" HANGER CLAMP-#2967
- 2) 360 SWINGER HANGER-BR91930
- 2) 3/8" X 3-1/2" BOLTS
- 2) 3/8" NUTS
- 2) 1/2" LARGE WASHERS (33012)
- 2) 3/8" FENDER WASHERS (33219)
- 2) 3/8" LOCK WASHERS
- 2) FRONT EXTENSION PIPES #485303-1
- 1) LEFT TAIL PIPE #G25076
- 1) RIGHT TAIL PIPE #G25083
- 2) TAIL PIPE EXTENSIONS
- 1) MUFFLER #54422

DANGER WARNING: SHOULD THE PURCHASER DECIDE TO INSTALL THIS, OR ANY OTHER EXHAUST PRODUCT AT HOME, BE WARNED THAT PLEASURE CAR OR LIGHT DUTY TRUCK/VAN "BUMPER JACKS" ARE INTENDED FOR EMERGENCY USE ONLY. THE USE OF FRAME CONTACT JACK STANDS IN CONJUNCTION WITH A FLOOR JACK AS MAIN SUPPORT IS HIGHLY RECOMMENDED TO MINIMIZE ACCIDENTAL DROPPING OF A VEHICLE WHILE THE INSTALLATION PROCEEDS.

Limitation of liability--Disclaimers: The regulation of emissions production, noise levels and safety standards is undertaken by the federal government, each of the fifty state legislatures, and by many local municipalities, towns and counties.

The manufacturer makes no warranties of merchantability, of fitness for a particular purpose, or that its products are approved for general use, or that its products comply with laws, regulations or ordinances in the states where they may be sold to the ultimate purchaser, the consumer.

The entire risk as to the conformity of this product in any such state and as to repair, should the product prove to be defective or non-conforming, is on the retail purchaser, the buyer, the ultimate consumer of such product and it is not upon the seller, distributor, or manufacturer.

In this connection, retail purchaser, the buyer, the ultimate consumer assumes the burden of the entire cost of any and all necessary service, alterations, and or repair.

The foregoing statement limits the liability of the manufacturer.

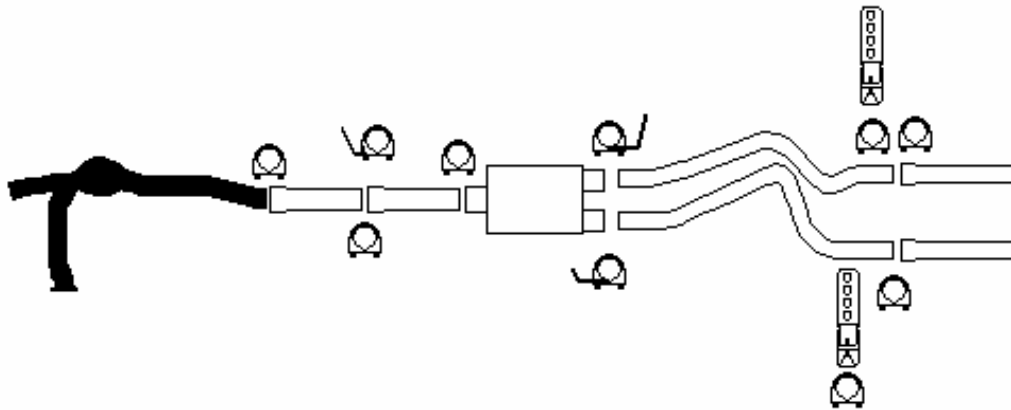

Heartthrob exhaust systems are manufactured by Heartthrob Exhaust--Litchfield, MN

Email us at mike@heartthrobexhaust.com with any questions. www.heartthrobexhaust.com

320-693-0222

**BUILD SHEET FOR: 2-1/2" CAT-BACK DUAL KIT
PART#'S: 2005015**

- _____ 1) LEFT TAIL PIPE #G25076
- _____ 1) RIGHT TAIL PIPE #G25083
- _____ 2) TAIL PIPE EXTENSIONS
- _____ 1) MUFFLER #54422
- _____ 2) FRONT EXTENSION PIPES#485303-1
- _____ 1) HARDWARE KIT

INSPECTED BY: _____

DATE _____

INSPECTED BY: _____

DATE _____

**BUILD SHEET FOR: 2-1/2" CAT-BACK DUAL KIT
PART#'S: 2005015**

- _____ 1) LEFT TAIL PIPE #G25076
- _____ 1) RIGHT TAIL PIPE #G25083
- _____ 2) TAIL PIPE EXTENSIONS
- _____ 1) MUFFLER #54422
- _____ 2) FRONT EXTENSION PIPES#485303-1
- _____ 1) HARDWARE KIT

INSPECTED BY: _____

DATE _____

INSPECTED BY: _____

DATE _____