

INSTRUCTIONS FOR KIT #2005724      DUAL KIT

FITS 1999-2005 FULL-SIZE GM 1/2 & 3/4 TON 2WD & 4WD PICKUPS W/4.3L V6, 4.8L & 5.3L V-8 ONLY WITH 2-3/4" FLANGED EXHAUST AT CONVERTER. THIS KIT FITS ONLY EXTENDED CAB SHORT BOX MODELS. DOES NOT FIT V-6, 5.7L, 8.1L, 6.0L.

**NOTE:** DO NOT TIGHTEN ANY CLAMPS OR BOLTS UNTIL THE LAST STEP!

- 1) REMOVE THE EXHAUST SYSTEM AT THE FLANGE BEHIND THE CONVERTERS LEAVING ONLY THE ORIGINAL Y PIPE, RUBBER MOUNTS, AND CATALYTIC CONVERTERS ON THE TRUCK. YOU WILL NEED TO REUSE THE ORIGINAL NUTS OFF OF THE O.E. FLANGE. DISCONNECT THE FACTORY HANGERS FROM THE ORIGINAL SYSTEM, LEAVING THE RUBBER HANGER MOUNTS IN PLACE.
- 2) SLIDE THE INCLUDED FORMED FLANGE ON THE FRONT EXTENSION PIE (3" PIPE WITH THE BALL FLARE ON ONE END). THE FLAT SIDE OF THE FORMED FLANGE GOES TOWARDS THE FRONT OF THE VEHICLE. YOU MAY NEED TO TAP THE FLANGE ONTO THE BALL JOINT WITH A HAMMER TO INSTALL. ROTATE THE PIPE TO CLEAR THE CROSS MEMBER AND INSTALL THE ORIGINAL NUTS LOOSELY ON THE FLANGE.
- 3) INSTALL THE MUFFLER TO THE EXTENSION PIPE.
- 4) INSTALL THE 3" HANGER CLAMP TO THE CONNECTING POINT OF THE EXTENSION PIPE AND THE MUFFLER AND CONNECT TO THE FRONT O.E. RUBBER MOUNT.
- 5) INSTALL THE LEFT TAIL PIPE (THE PIPE GOES UP AND OVER THE REAR DIFFERENTIAL, THE LONG END IS THE INLET AND IT HAS A SHALLOW BEND AT THE REAR) USING A 2-1/4" CLAMP TO THE LEFT OUTLET OF THE MUFFLER. THE LEFT TAIL PIPE GOES BETWEEN THE SPRING AND THE SHOCK. INSTALL THE LONG 2-1/4" HANGER CLAMP TO THE LEFT TAIL PIPE AFTER THE FIRST BEND IN THE PIPE AND CONNECT TO THE O.E. RUBBER MOUNT DIRECTLY ABOVE THE FIRST BEND IN THE LEFT TAIL PIPE.
- 6) LOCATE OR DRILL A HOLE IN THE FRAME NEAR THE LAST BEND OF THE LEFT TAIL PIPE. USING THE 5/16 X 1" BOLT, NUT, LOCK AND FENDER WASHER, INSTALL THE BR91930 (360 SWINGER HANGER) TO THE FRAME AND ATTACH TO THE LEFT TAIL PIPE USING A 2-1/4" CLAMP.
- 7) INSTALL THE RIGHT TAIL PIPE TO THE MUFFLER USING A 2-1/4" CLAMP. THE RIGHT TAIL PIPE HAS A SHALLOW BEND ON THE INLET, AND THE INLET IS THE SHORT END OF THE PIPE.
- 8) INSTALL THE SHORT HANGER CLAMP TO THE REAR O.E. RUBBER HANGER MOUNT. CLAMP THE HANGER TO THE RIGHT TAIL PIPE BEFORE THE LAST BEND.
- 9) INSTALL THE 30" I.D/O.D TAIL PIPE EXTENSIONS TO THE LEFT AND RIGHT TAIL PIPE USING 2-1/4" CLAMPS. (YOU WILL WANT TO TRIM THE EXTENSION TO YOUR DESIRED LENGTH.)
- 10) TIGHTEN ALL CLAMPS AND BOLTS AND CHECK FOR CLEARANCE OF THE FRAME, BODY, AND BRAKE AND FUEL LINES.

[www.heartthrobexhaust.com](http://www.heartthrobexhaust.com)

320-693-0222

**Heartthrob exhaust systems are manufactured by Heartthrob Exhaust--Litchfield, MN**

**Email us at [mike@heartthrobexhaust.com](mailto:mike@heartthrobexhaust.com) with any questions.**

**HARDWARE KIT FOR KIT #2005724:**

- 1) FRONT EXTENSION PIPE #1025750-1L
- 1) RIGHT TAIL PIPE #2008351-1
- 1) MUFFLER #54441
- 1) LEFT TAIL PIPE #2008351-2
- 2) TAIL PIPE EXTENSIONS #2008351-6
- 1) 3" HANGER CLAMP-#2955
- 5) 2-1/4" CLAMPS
- 1) BR91930 360 SWINGER HANGER
- 1) 5/16" X 1" BOLT
- 1) 5/16" NUT
- 1) FENDER WASHER (33219)
- 1) 5/16" LOCK WASHER
- 1) LONG 2-1/4" HANGER CLAMP # 2899
- 1) SHORT 2-1/4" HANGER CLAMP # 2898
- 1) FORMED FLANGE (SF36118)

**DANGER WARNING:** SHOULD THE PURCHASER DECIDE TO INSTALL THIS, OR ANY OTHER EXHAUST PRODUCT AT HOME, BE WARNED THAT PLEASURE CAR OR LIGHT DUTY TRUCK/VAN "BUMPER JACKS" ARE INTENDED FOR EMERGENCY USE ONLY. THE USE OF FRAME CONTACT JACK STANDS IN CONJUNCTION WITH A FLOOR JACK AS MAIN SUPPORT IS HIGHLY RECOMMENDED TO MINIMIZE ACCIDENTAL DROPPING OF A VEHICLE WHILE THE INSTALLATION PROCEEDS.

Limitation of liability--Disclaimers: The regulation of emissions production, noise levels and safety standards is undertaken by the federal government, each of the fifty state legislatures, and by many local municipalities, towns and counties.

The manufacturer makes no warranties of merchantability, of fitness for a particular purpose, or that its products are approved for general use, or that its products comply with laws, regulations or ordinances in the states where they may be sold to the ultimate purchaser, the consumer.

The entire risk as to the conformity of this product in any such state and as to repair, should the product prove to be defective or non-conforming, is on the retail purchaser, the buyer, the ultimate consumer of such product and it is not upon the seller, distributor, or manufacturer.

In this connection, retail purchaser, the buyer, the ultimate consumer assumes the burden of the entire cost of any and all necessary service, alterations, and or repair.

The foregoing statement limits the liability of the manufacturer.

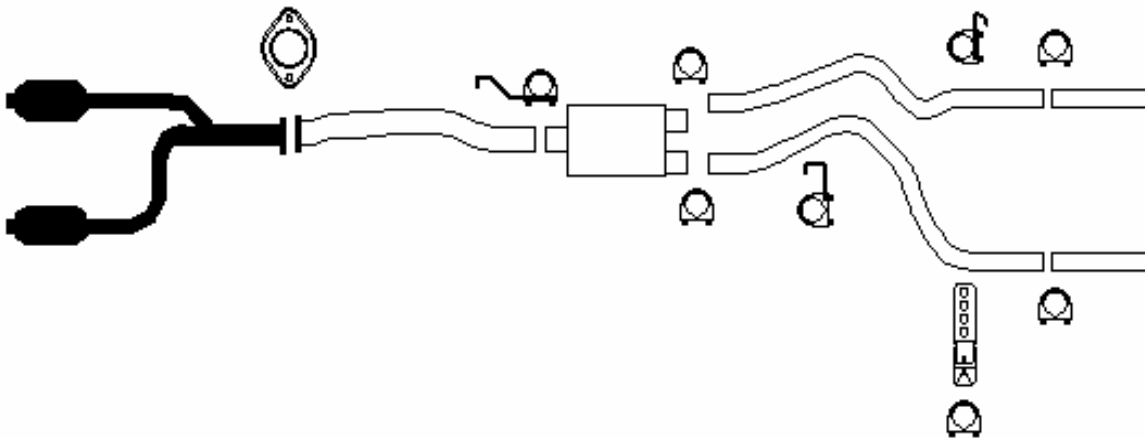

**BUILD SHEET FOR: CAT-BACK DUAL KITS**  
**PART #: 2005724**

- \_\_\_ 1) FRONT EXTENSION PIPE #1025750-1L
- \_\_\_ 1) LEFT TAIL PIPE #2008351-2
- \_\_\_ 1) RIGHT TAIL PIPE #2008351-1
- \_\_\_ 2) TAIL PIPE EXTENSIONS #2008351-6
- \_\_\_ 1) MUFFLER #54441
- \_\_\_ 1) HARDWARE KIT

INSPECTED BY: \_\_\_\_\_

DATE: \_\_\_\_\_

INSPECTED BY: \_\_\_\_\_

DATE: \_\_\_\_\_

**BUILD SHEET FOR: CAT-BACK DUAL KITS**  
**PART #: 2005724**

- \_\_\_ 1) FRONT EXTENSION PIPE #1025750-1L
- \_\_\_ 1) LEFT TAIL PIPE #2008351-2
- \_\_\_ 1) RIGHT TAIL PIPE #2008351-1
- \_\_\_ 2) TAIL PIPE EXTENSIONS #2008351-6
- \_\_\_ 1) MUFFLER #54441
- \_\_\_ 1) HARDWARE KIT

INSPECTED BY: \_\_\_\_\_

DATE: \_\_\_\_\_

INSPECTED BY: \_\_\_\_\_

DATE: \_\_\_\_\_