

## Instructions for kit #2005830 2-1/2" dual kit

Fits 2007 GM Silverado 1500 2wd & 4wd w/V6, 4.8L, 5.3L, 6.0L V-8 with 3" flanged exhaust at converters. This kit fits only 119" (standard cab standard 78.7" box) wheel base models.

**Note:** do not tighten any clamps or bolts until the last step! Support the vehicle in a safe manner, using either a shop hoist or jack stands that support the vehicle by the frame, on a level surface.

- 1) if you wish to remove the exhaust system in one piece, you will need to remove the spare tire, raise the rear of the vehicle to let the rear axle hang down (use only frame contact jack stands). Remove the M15 nuts on the front flange, and pull the exhaust to the rear to clear the front cross member, and drop the front down and forward to remove the exhaust. Replace the spare tire and you will then be ready to install your new exhaust system. Leave only the original y pipe, rubber mounts, and catalytic converters on the truck. You will need to reuse the original nuts off of the o.e. flange. Disconnect the factory hangers from the original system, leaving the rubber hanger mounts in place.
- 2) slide the included formed flange (#2876) on the 3" front extension pipe (3" pipe with the ball flare on one end). The flat side of the formed flange goes towards the front of the vehicle. You may need to tap the flange onto the ball joint with a hammer to install. Rotate the pipe to clear the cross member below and install the original nuts loosely on the flange.
- 3) install the muffler to the front extension pipe using the 3" clamp. Install the 3" hanger clamp to the front extension pipe, and attach the wire portion of the hanger to the o.e. rubber hanger mount above. The muffler inlet is offset, and the offset inlet should lie nearest the passenger side frame rail.
- 4) install the right (passenger side) tail pipe to the muffler outlet on the passenger side using the 2-1/2" right front hanger clamp for the passenger side. Attach the wire portion of the hanger to the o.e. rubber hanger mount above. The right tail pipe has 5 bends, the short end is the inlet, and it is routed between the shock and the spare tire. Install the 2-1/2" right rear hanger clamp to the right tail pipe just after the last bend, and connect the wire portion of the hanger to the o.e. mount above.
- 5) install the left (driver side) tail pipe to the muffler using the 2-1/2" left hanger clamp for the left side. Attach the wire portion of the hanger to the o.e. rubber hanger mount above.
- 6) Install the included BR92073 hanger to the frame, use an existing hole or drill one if needed. There is a large access hole above the left tail pipe, before the junction of the left tail pipe and the left tail pipe extension. Use the included hardware to mount the hanger to the frame, and a 2-1/2" clamp to connect the hanger to the left tail pipe below. The left tail pipe has 4 bends, the short end is the inlet, and it is routed between the shock and the spare tire.
- 7) install the tail pipe extensions to the left and right tail pipes by using the included 2-1/2" clamps.
- 8) tighten all clamps and bolts and check for clearance of the frame, body, and brake and fuel lines.

## 2-1/2" cat-back dual exhaust kit—rear exit

### 2005830

Limitation of liability—disclaimers: the regulation of emissions production, noise levels and safety standards is undertaken by the federal government, each of the fifty state legislatures, and by many local municipalities, towns and counties.

the manufacturer makes no warranties of merchantability, of fitness for a particular purpose, or that its products are approved for general use, or that its products comply with laws, regulations or ordinances in the states where they may be sold to the ultimate purchaser, the consumer.

the entire risk as to the conformity of this product in any such state and as to repair, should the product prove to be defective or non-conforming, is on the retail purchaser, the buyer, the ultimate consumer of such product and it is not upon the seller, distributor, or manufacturer.

in this connection, retail purchaser, the buyer, the ultimate consumer assumes the burden of the entire cost of any and all necessary service, alterations, and or repair.

the foregoing statement limits the liability of the manufacturer.

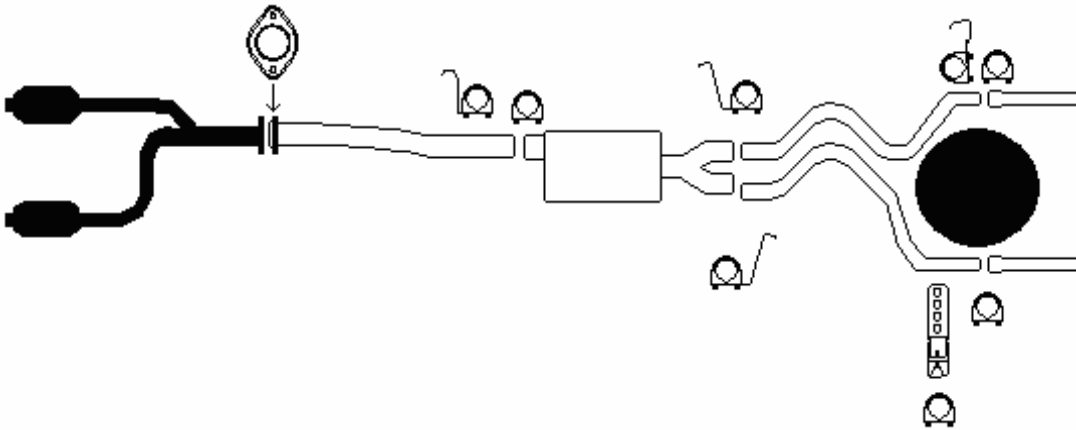

Heartthrob exhaust systems are manufactured by Heartthrob Exhaust—Litchfield, MN

Email us at [mike@heartthrobexhaust.com](mailto:mike@heartthrobexhaust.com) with any questions. [www.heartthrobexhaust.com](http://www.heartthrobexhaust.com)

320-693-0222

#### Hardware kit for kit #2005830:

- |   |                           |                             |
|---|---------------------------|-----------------------------|
| 1) 3" front extension pipe 2005831                | 1) left tail pipe 2005833 |                             |
| 1) right tail pipe 2005822                        | 1) muffler #58842Y        |                             |
| 2) tail pipe extensions 22" x 2.5" id/od #2005824 |                           |                             |
| 1) 2-1/2" left hanger clamp-# 2751                | 1) 3" hanger clamp-#2782  | 1) formed flange (#2876)    |
| 1) 2-1/2" right front hanger clamp-# 2750         | 3) 2-1/2" clamps          | 1) 33219 fender washer      |
| 1) 2-1/2" right rear hanger clamp-# 2779          | 1) BR92073 swinger hanger | 1) 10107 3/8" x 1-1/4" bolt |
| 1) 33622 lock washer                              | 1) #2778 washer bushing   | 1) 3" clamp                 |
| 1) 36106 3/8" nut                                 |                           |                             |

**Danger warning:** should the purchaser decide to install this, or any other exhaust product at home, be warned that pleasure car or light duty truck/van "bumper jacks" are intended for emergency use only. The use of frame contact jack stands in conjunction with a floor jack as main support is highly recommended to minimize accidental dropping of a vehicle while the installation proceeds.

**Build sheet for: 2-1/2" dual kits, split rear exit**

**Part #:2005830**

- \_\_\_\_\_ 1) 3" front extension pipe 2005831
- \_\_\_\_\_ 1) left tail pipe 2005833
- \_\_\_\_\_ 1) muffler #58842Y
- \_\_\_\_\_ 1) right tail pipe 2005822
- \_\_\_\_\_ 2) tail pipe extensions 22" x 2.5" id/od #2005824
- \_\_\_\_\_ 1) hardware kit

Inspected by: \_\_\_\_\_

Date: \_\_\_\_\_

Inspected by: \_\_\_\_\_

Date: \_\_\_\_\_

**Build sheet for: 2-1/2" dual kits, split rear exit**

**Part #:2005830**

- \_\_\_\_\_ 1) 3" front extension pipe 2005831
- \_\_\_\_\_ 1) left tail pipe 2005833
- \_\_\_\_\_ 1) muffler #58842Y
- \_\_\_\_\_ 1) right tail pipe 2005822
- \_\_\_\_\_ 2) tail pipe extensions 22" x 2.5" id/od #2005824
- \_\_\_\_\_ 1) hardware kit

Inspected by: \_\_\_\_\_

Date: \_\_\_\_\_

Inspected by: \_\_\_\_\_

Date: \_\_\_\_\_