

KIT #8144680

THIS KIT FITS: PONTIAC FIREBIRD--1967-1968 w/V8, excluding Ram Air models

1) **note:** the mufflers are not supplied with this exhaust system. This kit has been designed for use with turbo mufflers or an equivalent 2-1/4" id inlet by 2-1/4" id outlet double offset muffler.

2) **note:** we recommend welding (tack welding) the slip joints, although not necessary.

Danger warning: installation of the exhaust may facilitate raising your vehicle. A floor hoist is ideal. If no hoist is available, we strongly recommend the use of axle stands as a safety measure. Should the purchaser decide to install this exhaust product at home, be warned that pleasure car or light duty truck/van "bumper" jacks are intended for emergency use only. The use of frame contact jack stands in conjunction with a floor jack as main support is highly recommended to minimize accidental dropping of a vehicle while the installation proceeds.

HARDWARE KIT:

- | | |
|---------------------------------------|----------------------------------|
| 2) LB4 HANGERS | 1) #8144681 LEFT MANIFOLD PIPE |
| 2) SNAPPER GROMMETS # ba120 | 1) #8144682 RIGHT MANIFOLD PIPE |
| 2) 5/16" X 1-1/2" lag screw # 0142256 | 1) #8144683 LEFT EXTENSION PIPE |
| 10) 2-1/4" CLAMPS | 1) #8144684 RIGHT EXTENSION PIPE |
| 2) BR709 swinger hangers | 1) #8144686 RIGHT TAIL PIPE |
| 2) 5/16" x 1" bolt # 10055 | 1) #8144685 LEFT TAIL PIPE |
| 2) fender washer # 33219 | |

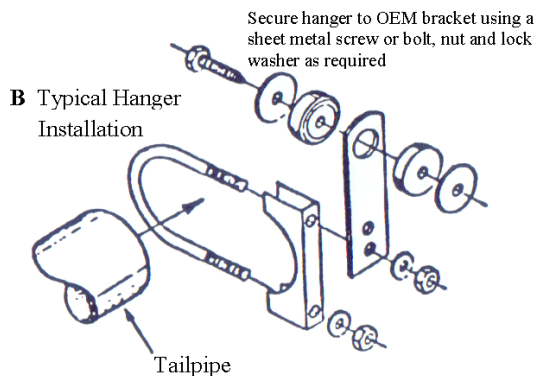

Heartthrob exhaust systems are manufactured by Heartthrob Exhaust--Litchfield, MN

Email us at mike@heartthroboxhaust.com with any questions. www.heartthroboxhaust.com

320-693-0222

Limitation of liability-disclaimers: the regulation of emissions production, noise levels and safety standards is undertaken by the federal government, each of the fifty state legislatures, and by many local municipalities, towns and counties.

the manufacturer makes no warranties of merchantability, of fitness for a particular purpose, or that its products are approved for general use, or that its products comply with laws, regulations or ordinances in the states where they may be sold to the ultimate purchaser, the consumer.

the entire risk as to the conformity of this product in any such state and as to repair, should the product prove to be defective or non-conforming, is on the retail purchaser, the buyer, the ultimate consumer, of such product and it is not upon the seller, distributor, or manufacturer.

in this connection, the retail purchaser, the buyer, the ultimate consumer assumes the burden of the entire cost of any and all necessary service, alterations and or repair.

the foregoing statement limits the liability of the manufacturer.

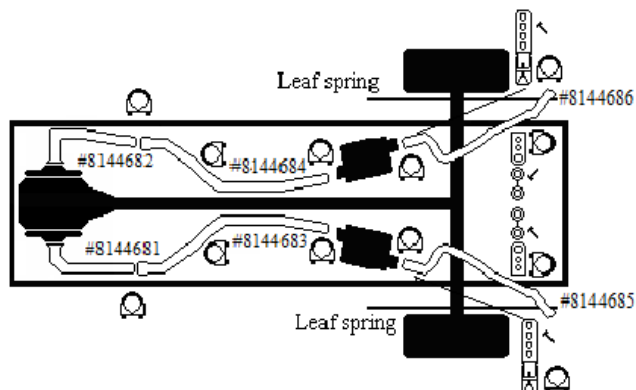

KIT # 8144680

INSTALLATION INSTRUCTIONS:

NOTE: DO NOT TIGHTEN ANY CLAMPS OR NUTS UNTIL THE LAST STEP!!

- 1) remove the old exhaust system and save the old flanges.
 - 2) install the left (#8144681—flared pipe with two bends really close to each other) and right (#8144682—flared pipe with two bends further away from each other) manifold pipes using the old flanges. Tighten only enough to hold in place. If flanges are needed, order separately, # sf67007.
 - 3) install the left (#8144683—3-bend pipe) and right (#8144684—3 bend pipe) front extension pipes to the manifold pipes using 2-1/4” clamps. Be sure to leave adequate clearance between the floor boards and the drive shaft.
 - 4) install the mufflers (double offset turbo-type recommended--not included in this kit) onto the extension pipes using 2-1/4” clamps. Rotate the front extension pipes to clear the driveshaft, and frame, and general clearance.
 - 5) install the left (#8144685) and right (#8144686) tail pipes to the mufflers using 2-1/4” clamps.
 - 6) mount the br709 hanger brackets to the existing holes in the frame in front of the rear axle using the 5/16” x 1” bolt and washer, and attach to the tail pipes using 2-1/4” clamps.
 - 7) the lb4 hanger and snapper grommet hangers should be installed to the tail pipes at where the tail pipes cross under the frame. You will need to drill a 3/16” hole in the frame for the lag screw. Use the included lag screws and LB4 and snapper grommet setup, and attach to the tail pipe using the remaining 2-1/4” clamps.
 - 8) make sure that all the parts of the system are clear of frame members, all hoses, suspension, and brake and fuel lines.
- Starting at the manifold pipes, tighten all connections and nuts. Make sure all parts are clear and will not leak or rattle. After several days of driving retighten all bolts.

Build sheet for: 2-1/4” manifold dual kit

Part# 8144680

- _____ 1) #8144681 left MANIFOLD pipe
- _____ 1) #8144682 right MANIFOLD pipe
- _____ 1) #8144683 left extension pipe—requires a label
- _____ 1) #8144684 right extension pipe—requires a label
- _____ 1) #8144686 RIGHT TAIL PIPE
- _____ 1) #8144685 LEFT TAIL PIPE
- _____ 1) hardware kit

Inspected by: _____

Date: _____