

KIT # 8168720**3" Dual Exhaust Kit No Mufflers**

This kit fits B-body, '68-'74 Charger, GTX, Coronet, Belvedere, Satellite, Roadrunner, Super Bee, R/T, all with V8, standard headers, and with 3" collectors at the headers. For those with 3-1/2" collectors, you will need to purchase an additional header collector kit.

NOTE: THE HEADERS ARE NOT INCLUDED IN THIS KIT!! **We recommend use of Hooker Super Competition headers. Modifications may need to be made for different styles of headers, including cutting and welding. For vehicles with 3-1/2" collectors, you will need to order a 3-1/2" header collector kit. Mufflers are not included in this kit, approximate body size is a 14" long body, 4-1/4" x 9-3/4", offset in/center outlet muffler.**

DANGER WARNING: SHOULD THE PURCHASER DECIDE TO INSTALL THIS EXHAUST PRODUCT AT HOME, BE WARNED THAT PLEASURE CAR OR LIGHT DUTY TRUCK/VAN "BUMPER" JACKS ARE INTENDED FOR EMERGENCY USE ONLY. THE USE OF FRAME CONTACT JACK STANDS IN CONJUNCTION WITH A FLOOR JACK AS MAIN SUPPORT IS HIGHLY RECOMMENDED TO MINIMIZE ACCIDENTAL DROPPING OF A VEHICLE WHILE THE INSTALLATION PROCEEDS.

HARDWARE KIT:

- 2) BR104 RUBBER HANGERS
- 2) BR91930 SWINGER HANGERS
- 1) 5/16" X 1" LAG SCREW
- 3) BR755 METAL HANGER BRACKET
- 14) 3" CLAMPS
- 2) F33 FLANGES
- 6) 3/8" NUTS
- 6) 3/8" LOCKWASHERS
- 6) 3/8" X 1-1/4" BOLTS
- 7) 5/16" LOCK WASHERS
- 7) 5/16" X 1" BOLTS
- 7) 5/16" NUTS
- 2) HEADER COLLECTORS—3"-3"
- 2) #MP48005 3" COLLECTOR GASKETS

PIPE KIT:

- 1) LEFT FRONT EXTENSION PIPE--#8168721
- 1) RIGHT FRONT EXTENSION PIPE--#8168722
- 1) LEFT REAR EXTENSION PIPE--#8168723
- 1) RIGHT REAR EXTENSION PIPE--#8168724
- 1) LEFT TAIL PIPE--#8168727
- 1) RIGHT TAIL PIPE--#8168728
- 1) RIGHT OVER THE AXLE PIPE--#8168726
- 1) LEFT OVER THE AXLE PIPE--#8168725

O.E. hangers may be re-used. Hanger # BR91930 will need to be bent for fitment with an offset S-bend. For vehicles originally equipped with factory single exhaust, the additional BR755 hanger bracket will be necessary.

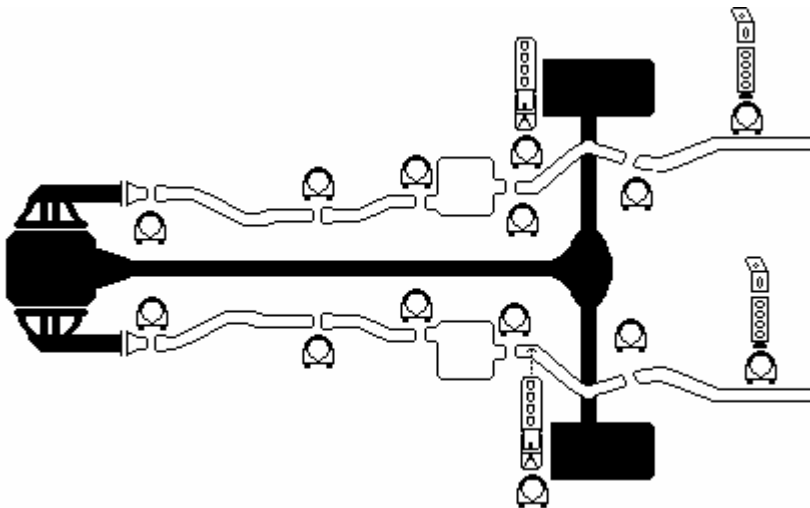

Heartthrob exhaust systems are manufactured by Heartthrob Exhaust--Litchfield, MN

Email us at mike@heartthrobexhaust.com with any questions. www.heartthrobexhaust.com

320-693-0222

KIT #8168720

INSTALLATION INSTRUCTIONS:

NOTE: DO NOT TIGHTEN ANY CLAMPS OR NUTS UNTIL THE LAST STEP!!

- 1) RAISE THE AUTOMOBILE IN A SAFE AND SUITABLE MANNER--SUPPORT WITH JACK STANDS ONTO THE FRAME.
- 2) REMOVE THE OLD EXHAUST SYSTEM AFTER THE HEADERS. REMOVE THE OLD HANGERS AND BRACKETS IF DESIRED. NEW UNIVERSAL HANGERS ARE INCLUDED IN THIS KIT TO REPLACE THE ORIGINAL HANGERS.
- 3) INSTALL THE COLLECTORS TO THE HEADERS USING THE MP48005 GASKETS AND F33 FLANGES, AND ENCLOSED HARDWARE. TIGHTEN ONLY AT THIS TIME, USING THE 3/8" X 1-1/4" BOLTS AND NUTS.
- 4) INSTALL THE I.D. ENDS OF THE LEFT (#8168721) AND RIGHT (#8168722) FRONT EXTENSION PIPES TO THE COLLECTORS USING 3" CLAMPS. BE SURE TO LEAVE ADEQUATE CLEARANCE BETWEEN THE FLOOR BOARDS, THE DRIVE SHAFT, AND THE CROSSMEMBER. THE LEFT FRONT EXTENSION PIPE SHOULD JUST CLEAR THE RECESS IN THE CROSSMEMBER. NOTE: IF THESE PIPES DO NOT FIT YOUR HEADERS, YOU MAY NEED TO MODIFY AS NECESSARY (CUT AND WELD) FOR FIT. THESE KITS WERE DESIGNED FOR USE WITH HOOKER SUPER COMPETITION HEADERS.
- 5) INSTALL THE I.D. ENDS OF THE LEFT (#8168723) AND RIGHT (#8168724) REAR EXTENSION PIPES TO THE LEFT AND RIGHT FRONT EXTENSION PIPES, USING 3" CLAMPS.
- 6) INSTALL THE MUFFLERS (OFFSET IN, TOWARDS DRIVE SHAFT/CENTER OUT, NOT INCLUDED) ONTO THE REAR EXTENSION PIPES USING 3" CLAMPS. ROTATE THE EXTENSION PIPES TO CLEAR THE DRIVESHAFT, AND FRAME, AND GENERAL CLEARANCE.
- 7) INSTALL THE LEFT (#8168725) AND RIGHT (#8168726) OVER THE AXLE PIPES TO THE MUFFLERS USING 3" CLAMPS.
- 8) MOUNT THE HANGER BRACKETS IF NECESSARY (IF YOU ARE NOT RE-USING THE FACTORY HANGERS) TO THE LEFT AND RIGHT O.E. MOUNTS AFTER THE AXLE USING THE BR91930 HANGERS. THESE HANGERS WILL NEED TO BE BENT IN AN OFFSET S-BEND FOR CLEARANCE, THESE HANGERS SHOULD BE MOUNTED TO THE O.E. MOUNTS ABOVE USING 5/16" X 1" BOLTS, NUTS, AND LOCK WASHERS. CONNECT THE HANGERS TO THE OVER THE AXLE PIPES USING 3" CLAMPS, JUST BEFORE THE FIRST BEND IN THE OVER THE AXLE PIPE AND JUST AFTER THE CLAMPED JOINT AT THE MUFFLER AND OVER THE AXLE PIPE. NOTE: IF YOUR CAR WAS NOT EQUIPPED WITH FACTORY DUAL EXHAUST, A HANGER BRACKET (BR755) AND LAG SCREW WILL NEED TO BE INSTALLED AS A MIRROR IMAGE OF THE RIGHT SIDE O.E. TO THE FLOOR BOARD.
- 9) INSTALL THE LEFT (#8168727) AND RIGHT (#8168728) TAIL PIPES TO THE OVER THE AXLE PIPES USING 3" CLAMPS. USE A 3" CLAMP TO CONNECT THE PIPES AND AN O.E. HANGER AT THE REAR, OR INSTALL THE BR755 BRACKET (IF NECESSARY, OR RE-USE O.E.) TO THE VEHICLE, AND A BR104 RUBBER HANGER TO THE BR755 USING 5/16" X 1" BOLTS, NUTS, AND LOCK WASHERS. CUT THE TAIL PIPES TO YOUR DESIRED LENGTH AND LOOK.
- 10) MAKE SURE THAT ALL THE PARTS OF THE SYSTEM ARE CLEAR OF FRAME MEMBERS, THE CROSS MEMBER, DRIVESHAFT, FLOOR, ALL HOSES, SUSPENSION, AND BRAKE AND FUEL LINES. STARTING AT THE COLLECTOR PIPES, TIGHTEN ALL CONNECTIONS AND NUTS. MAKE SURE ALL PARTS ARE CLEAR AND WILL NOT LEAK OR RATTLE. AFTER SEVERAL DAYS OF DRIVING RETIGHTEN ALL BOLTS.

LIMITATION OF LIABILITY-DISCLAIMERS: THE REGULATION OF EMISSIONS PRODUCTION, NOISE LEVELS AND SAFETY STANDARDS IS UNDERTAKEN BY THE FEDERAL GOVERNMENT, EACH OF THE FIFTY STATE LEGISLATURES, AND BY MANY LOCAL MUNICIPALITIES, TOWNS AND COUNTIES.

THE MANUFACTURER MAKES NO WARRANTIES OF MERCHANTABILITY, OF FITNESS FOR A PARTICULAR PURPOSE, OR THAT ITS PRODUCTS ARE APPROVED FOR GENERAL USE, OR THAT ITS PRODUCTS COMPLY WITH LAWS, REGULATIONS OR ORDINANCES IN THE STATES WHERE THEY MAY BE SOLD TO THE ULTIMATE PURCHASER, THE CONSUMER.

THE ENTIRE RISK AS TO THE CONFORMITY OF THIS PRODUCT IN ANY SUCH STATE AND AS TO REPAIR, SHOULD THE PRODUCT PROVE TO BE DEFECTIVE OR NON-CONFORMING, IS ON THE RETAIL PURCHASER, THE BUYER, THE ULTIMATE CONSUMER, OF SUCH PRODUCT AND IT IS NOT UPON THE SELLER, DISTRIBUTOR, OR MANUFACTURER.

IN THIS CONNECTION, THE RETAIL PURCHASER, THE BUYER, THE ULTIMATE CONSUMER ASSUMES THE BURDEN OF THE ENTIRE COST OF ANY AND ALL NECESSARY SERVICE, ALTERATIONS AND/OR REPAIR.

THE FOREGOING STATEMENT LIMITS THE LIABILITY OF THE MANUFACTURER.

CALIFORNIA VEHICLE CODE SECTION 27156 PROHIBITS THE ADVERTISING, OFFERING FOR SALE, OR INSTALLATION OF ANY DEVICE WHICH MODIFIES A VEHICLE'S EMISSION CONTROL SYSTEM. THIS PRODUCT IS THEREFORE NOT LEGAL FOR SALE OR USE IN CALIFORNIA ON VEHICLES EQUIPPED WITH CATALYTIC CONVERTERS.

BUILD SHEET FOR: 3" HEADER DUAL KITS

PART #'S: 8168720

- _____ 1) LEFT FRONT EXTENSION PIPE--#8168721
- _____ 1) RIGHT FRONT EXTENSION PIPE--#8168722
- _____ 1) LEFT REAR EXTENSION PIPE--#8168723
- _____ 1) RIGHT REAR EXTENSION PIPE--#8168724
- _____ 1) LEFT TAIL PIPE--#8168727
- _____ 1) RIGHT TAIL PIPE--#8168728
- _____ 1) LEFT OVER THE AXLE PIPE--#8168725
- _____ 1) RIGHT OVER THE AXLE PIPE--#8168726
- _____ 1) Hardware kit

INSPECTED BY: _____

DATE: _____

INSPECTED BY: _____

DATE: _____

BUILD SHEET FOR: 3" HEADER DUAL KITS

PART #'S: 8168720

- _____ 1) LEFT FRONT EXTENSION PIPE--#8168721
- _____ 1) RIGHT FRONT EXTENSION PIPE--#8168722
- _____ 1) LEFT REAR EXTENSION PIPE--#8168723
- _____ 1) RIGHT REAR EXTENSION PIPE--#8168724
- _____ 1) LEFT TAIL PIPE--#8168727
- _____ 1) RIGHT TAIL PIPE--#8168728
- _____ 1) LEFT OVER THE AXLE PIPE--#8168725
- _____ 1) RIGHT OVER THE AXLE PIPE--#8168726
- _____ 1) Hardware kit

INSPECTED BY: _____

DATE: _____

INSPECTED BY: _____

DATE: _____